

RED ROOSTER AIR CHAIN HOISTS

TMH-25

WLL	Lifting speed with load	Lifting speed without load	Lowering speed with load	Air consumption lifting	Air consumption lowering	Air connection
25.000 kg	1,4 m/min	2,7 m/min	3 m/min	108 l/sec	180 l/sec	PT 1½"
Minimum hose diam.	Chain falls	Chain size mm	Working pressure	Weight with 3 m hol	Additional meter hol	-
PT 1½"	2	23,5 x 66 mm	4 - 6 bar	581 kg	24,4 kg	-

Information subject to change without notice

DIMENSIONS IN MM

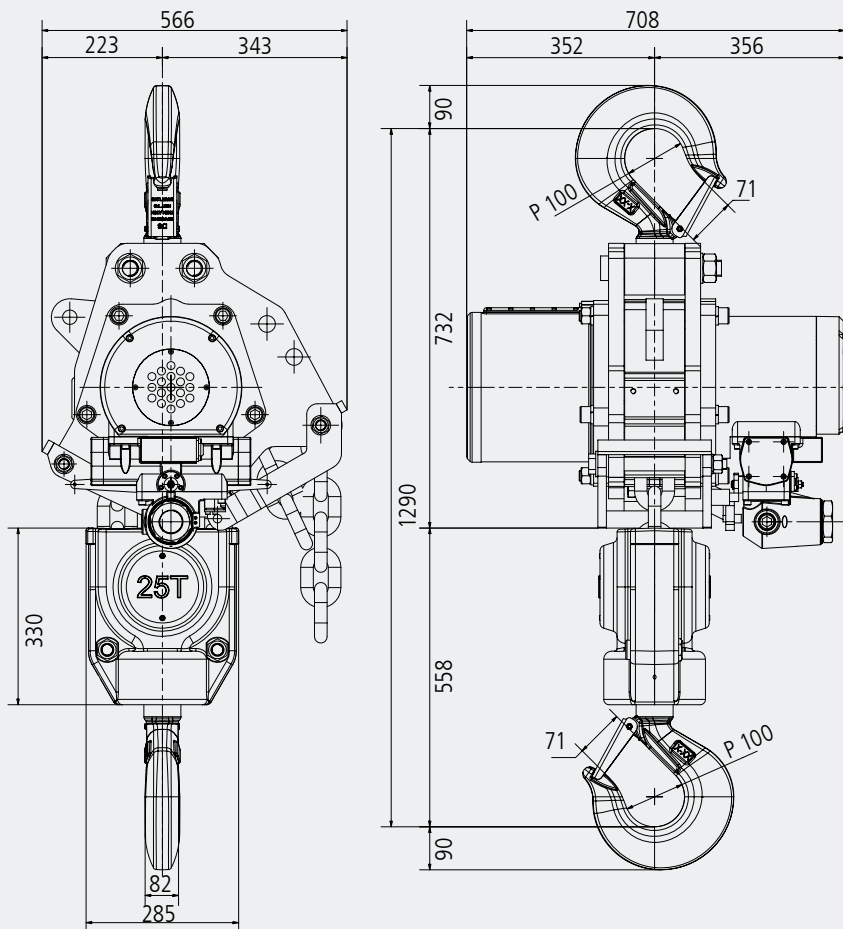

All measurements are in mm / Information subject to change without notice

